



# HOSHIZAKI

# THE DURABLE & DEPENDABLE HIGH PERFORMERS

The IM series come in multiple self-contained, modular and stackable options, the series is considered to be a true allrounder – suitable for all requirements, purposes, locations and budgets.



## IM SERIES

Cubers and Special icemakers



## MEET THE HOSHIZAKI CUBE

Every bartender will tell you about the importance of the ice quality for their craft of creating layers of taste and texture in a cocktail glass. Premium spirits and ingredients simply ask to be paired with nothing less than ice cube perfection. Hoshizaki cubes are extremely compact, dry, tasteless, consistently identical and slowly melting, allowing just the right amount of dilution – a combination of everything a bartender requires when it comes to aesthetics, taste and functionality of ice.

## ABOUT THE RANGE

All Cubers are equipped with an electronic control system. This ensures an optimised ice making process, even under varying circumstances. Without additional manual assistance or adjustments required, our Cubers produce generous amounts of ice cubes, at a consistent high quality. The Automatic Rinse Cycle in our Hoshizaki Cube ice makers, flushes new water through at the beginning of each and every cubing process to reduce impurities. This process assists with lowering the development rate of calcification, mineral accumulation and incrustation.

As with all Hoshizaki Ice Makers, the Cubers are HACCP certified and known for continuously meeting the highest health, safety and hygiene standards.

As Hoshizaki Cubers come in multiple self-contained, modular & stackable options, the series is considered to be a true allrounder - suitable for all requirements, purposes, locations and budgets.

### STABLE MATERIALS AND DURABLE DESIGN



The devices are designed to last and come with smart design extras such as a magnetic water pump without direct coupling. This element prevents leakage from the water circuit and improves the life expectancy of the device.

### RANGE PRODUCTION CAPACITY



The series consists of Cubers with production capacities, ranging from 18 - 205 kg per day.

IM-240ANE/DNE units can be double or triple stacked to increase daily production rates.

### HIGHEST HYGIENE STANDARDS & EASY MAINTENANCE



The exteriors are made of stainless steel. Also the closed water circuit provides maximum protection against any type of contamination during the entire cubing process. All Hoshizaki machines are easy to use, clean and maintain.





## ABOUT THE ICE

### PERFECT TASTE



Being free of all impurities, our cubes are a perfectly tasteless chilling agent for all types of culinary purposes without compromising the taste of your creation.

### PERFECT SHAPE

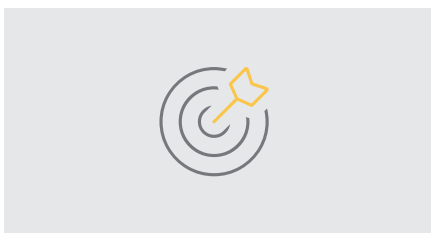

Each cube is made individually by a dedicated spray of fresh water within a closed cell to achieve the highest possible compactness of an ice cube with the perfectly precise square shape.

### PERFECT DILUTION

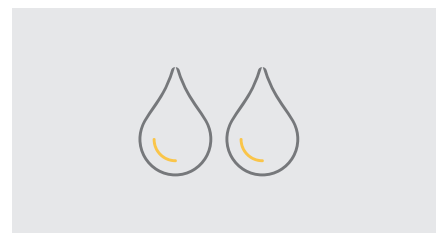

During the freezing process, the cell walls block the freezing water's expansion from all sides. This makes Hoshizaki ice cubes so exceptionally compact and hard, that they provide the exact rate of dilution needed for cocktails and long drinks.

*The appearance of the Hoshizaki cube is characterized by its clean edges and its transparency streaked by a marbling effect. This effect occurs, when the cell walls block the freezing water's expansion from all sides, while reaching up to  $-30^{\circ}\text{C}$  during the cubing process. As the temperatures go down, the water keeps expanding and marbles start to form as a sign of extreme density and compactness of every single cube.*

1



2

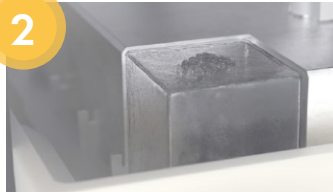

3



4

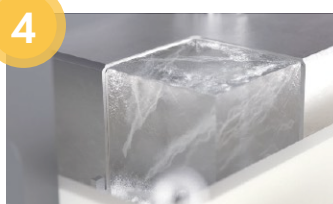

## PERFECT TASTE



## PERFECT SHAPE



## PERFECT DILUTION



### CUBE SIZES

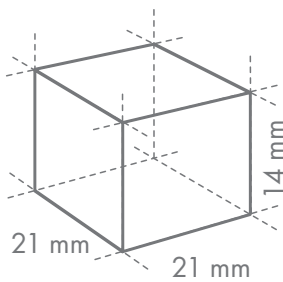

Cube size: **XS**  
Weight: 6 g

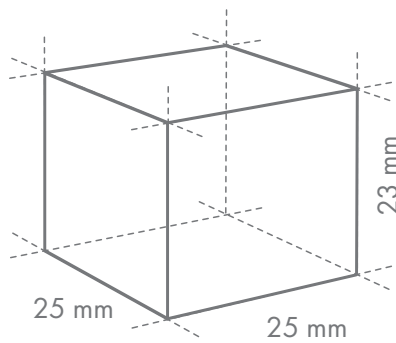

Cube Size: **S**  
Weight: 13 g

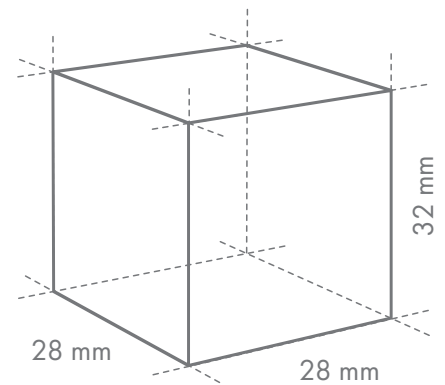

Cube Size: **L**  
Weight: 23 g

*Specially tailored for cocktail bars that like to differentiate themselves from others, whilst never compromising on taste and quality of their drinks.*

### SPECIAL ICE

Ice type:  
Big Cube **XXL**  
Weight: 120 g

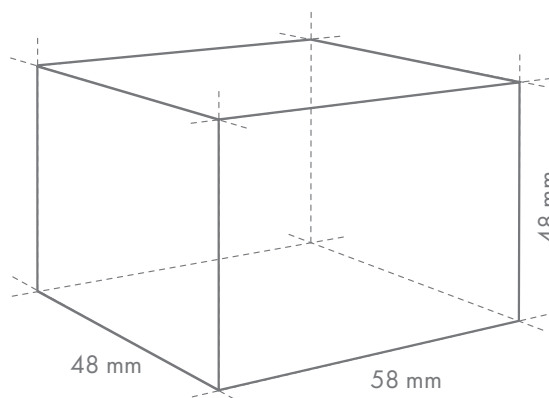

Ice type: Ball  
Weight: 45 g

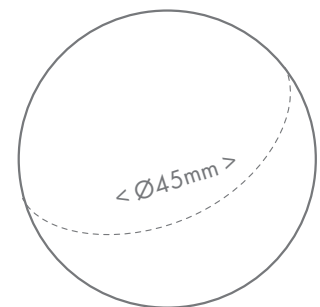

# IM SERIES KEY SPECS



Self contained

## IM-30CNE



Production capacity/24 h\*:  
18 kg  
Bin capacity: 11,5 kg  
Cube Size: **S**  
S - 91000001 IM-30CNE-25

\*Height includes 92-127mm Legs



Self contained

## IM-45CNE



Production capacity/24 h\*:  
32 kg  
Bin capacity: 15 kg  
Cube Size: **S**  
S - 91000090 IM-45CNE-25

\*Height includes 90-125mm Legs



Self contained

## IM-65NE

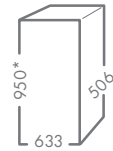

Production capacity/24 h\*:  
S/44kg L/33kg B/24kg  
Bin capacity:  
S/26kg L/26kg B/17kg  
Cube Size: **S** **XXL** **Ball**  
S - 91000097 IM-65NE-25  
L - 91000122 IM-65NE-LM  
Ball - 91000096 IM-65NE-Q

\*Height includes 90-125mm Legs  
LM & Q Models 980 H



Self contained

## IM-100CNE



Production capacity/24 h\*:  
XS/85kg L/83kg  
Bin capacity: 38 kg  
Cube Size: **XS** **L**  
XS - 91000117 IM-100CNE-21  
L - 91000114 IM-100CNE-28

\*Height includes 90-125mm Legs



Self contained

## IM-130NE



Production capacity/24 h\*:  
XS/95kg L/104kg  
Bin capacity: 50 kg  
Cube Size: **XS** **L**  
XS - 91000118 IM-130NE-21  
L - 91000106 IM-130NE-28

\*Height includes 70-110mm Legs



Self contained

## IM-240NE



Production capacity/24 h\*:  
XS/180kg L/205kg  
Bin capacity: 110 kg  
Cube Size: **XS** **L**  
XS - 91000112 IM-240NE-21  
L - 91000091 IM-240NE-28

\*Height includes 70-110mm Legs

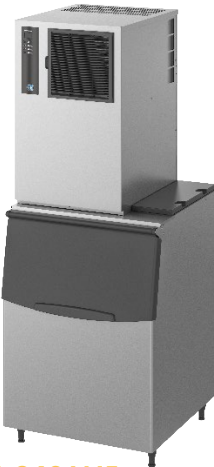

Modular

## IM-240ANE



Production capacity/24 h\*:  
205 kg  
Bin: choose bin B301, B501, B801  
Cube Size: **L**  
L - 91000098 IM-240ANE-28

\*Specs exclude bin size

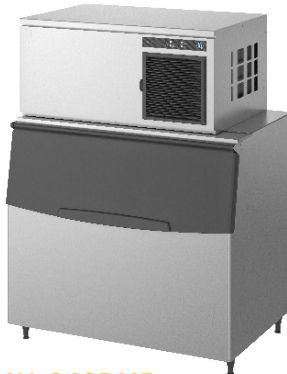

Stackable

## IM-240DNE



Production capacity/24 h\*:  
205 kg  
Bin: choose bin B801  
Multiple machines can be stacked\*  
Cube Size: **L**  
L - 91000109 IM-240DNE-28

\*Specs exclude bin size

\*Requires the use of IM-240DNE + IM-240XNE combination.



Stackable

## IM-240XNE



Production capacity/24 h\*:  
205 kg  
Bin: choose bin B801  
Multiple machines can be stacked  
Cube Size: **L**  
L - 91000913 IM-240XNE-28

\*Specs exclude bin size

\*For use only when double/triple stacking of IM240DNE

Production rates based on 21°C Air/15°C Water. Production rates and bin capacity vary according to ice cube size. Please refer to individual product specification sheets for individual model details.





# HOSHIZAKI



**Proudly distributed by**

**Ice Machines Australia**

T: 1300 721 752

[info@icemakers.com.au](mailto:info@icemakers.com.au)  
[www.icemakers.com.au](http://www.icemakers.com.au)